

MBL800E33D

Silicon N-channel IGBT

FEATURES

- * High thermal fatigue durability.($\Delta T_c=70^\circ\text{C}$, $N>30,000$ cycles)
- * High speed, low loss IGBT module.
- * Low noise due to built-in free-wheeling diode
 - ultra soft fast recovery diode(USFD).
- * Low driving power due to low input capacitance MOS gate.
- * High reliability, high durability module.
- * Isolated heat sink(terminal to base).

ABSOLUTE MAXIMUM RATINGS ($T_c=25^\circ\text{C}$)

Item	Symbol	Unit	MBL800E33D
Collector Emitter Voltage	V _{CES}	V	3,300
Gate Emitter Voltage	V _{GES}	V	± 20
Collector Current	DC	I _C	800
	1ms	I _{Cp}	1,600
Forward Current	DC	I _F	800
	1ms	I _{FM}	1,600
Junction Temperature	T _j	$^\circ\text{C}$	-40 ~ +125
Storage Temperature	T _{stg}	$^\circ\text{C}$	-40 ~ +125
Isolation Voltage	V _{ISO}	V _{RMS}	6,000(AC 1 minute)
Screw Torque	Terminals (M4/M8)	-	2/10 (1)
	Mounting (M6)	-	6 (2)

Notes: (1) Recommended Value $1.8\pm 0.2/9\pm 1\text{N}\cdot\text{m}$ (2) Recommended Value $5.5\pm 0.5\text{N}\cdot\text{m}$

ELECTRICAL CHARACTERISTICS

1) IGBT + FWD

Item	Symbol	Unit	Min.	Typ.	Max.	Test Conditions
Collector Emitter Cut-Off Current	I _{CES}	mA	-	-	12.0	V _{CE} =3,300V, V _{GE} =0V, T _j =25 $^\circ\text{C}$
Gate Emitter Leakage Current	I _{GES}	nA	-500	-	+500	V _{GE} = $\pm 20\text{V}$, V _{CE} =0V, T _j =25 $^\circ\text{C}$
Collector Emitter Saturation Voltage	V _{CE(sat)}	V	-	4.2	5.2	I _C =800A, V _{GE} =15V, T _j =125 $^\circ\text{C}$
Gate Emitter Threshold Voltage	V _{GE(TO)}	V	4.5	6.0	7.0	V _{CE} =10V, I _C =800mA, T _j =25 $^\circ\text{C}$
Input Capacitance	C _{ies}	nF	-	75	-	V _{CE} =10V, V _{GE} =0V, f=100kHz, T _j =25 $^\circ\text{C}$
Internal Gate Resistance	R _{ge}	Ω	-	1.8	-	
Switching Times	Rise Time	t _r	-	1.9	3.1	V _{CC} =1,650V, I _C =800A
	Turn On Time	t _{on}	-	2.4	3.3	L=120nH
	Fall Time	t _f	-	1.0	2.5	R _G =4.7 Ω (3)
	Turn Off Time	t _{off}	-	3.0	5.1	V _{GE} = $\pm 15\text{V}$, T _j =125 $^\circ\text{C}$
Peak Forward Voltage Drop	V _{FM}	V	-	2.5	3.0	-I _C =800A, V _{GE} =0V, T _j =125 $^\circ\text{C}$
Reverse Recovery Time	t _{rr}	μs	-	0.6	1.1	V _{CC} =1,650V, I _F =800A (4) L=120nH, T _j =125 $^\circ\text{C}$
Thermal Impedance	IGBT	R _{th(j-c)}	-	-	0.013	Junction to case
	FWD	R _{th(j-c)}	-	-	0.026	

2) DIODE

Item	Symbol	Unit	Min.	Typ.	Max.	Test Conditions
Collector Emitter Cut-Off Current	I _{AKS}	mA	-	-	12.0	V _{AK} =3,300V, T _j =25 $^\circ\text{C}$
Peak Forward Voltage Drop	V _F	V	-	2.9	3.4	I _F =800A, T _j =125 $^\circ\text{C}$ At Main terminal (Terminal resistance:0.5m Ω typical)
Reverse Recovery Time	t _{rr}	μs	-	0.6	1.1	I _F =800A, V _{CC} =1,650V (4) L=120nH, T _j =125 $^\circ\text{C}$
Thermal Impedance	R _{th(j-c)}	K/W			0.026	Junction to case

Notes: (3) R_G value is the test condition's value for decision of the switching times, not recommended value. Please, determine the suitable R_G value after the measurement of switching waveforms(overshoot voltage, etc.)with appliance mounted.
(4)Counter arm IGBT V_{GE}= $\pm 15\text{V}$

* Please contact our representatives at order.

* For improvement, specifications are subject to change without notice.

* For actual application, please confirm this spec sheet is the newest revision.

MBL800E33D

DEFINITION OF TEST CIRCUIT

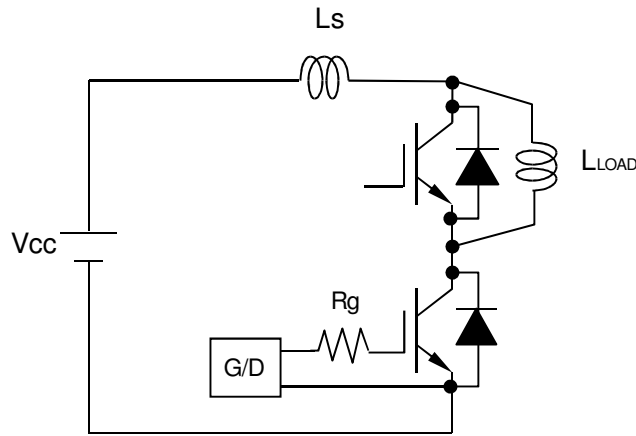

Fig.1 Switching test circuit

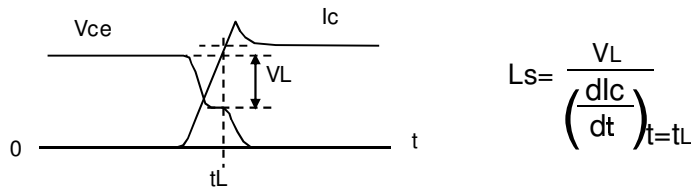

Fig.2 Definition of Ls

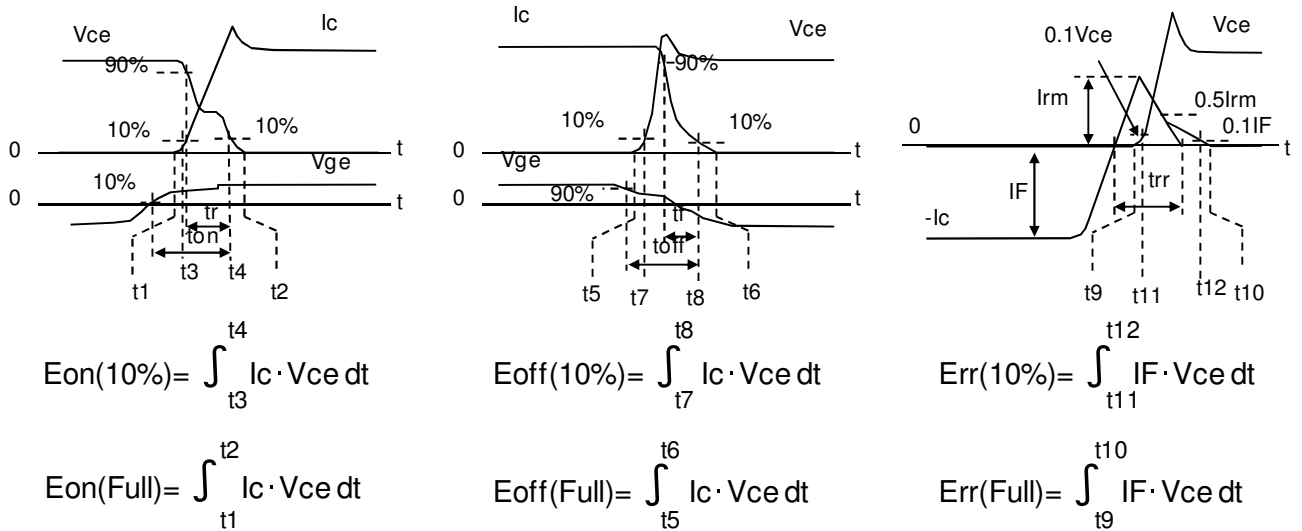
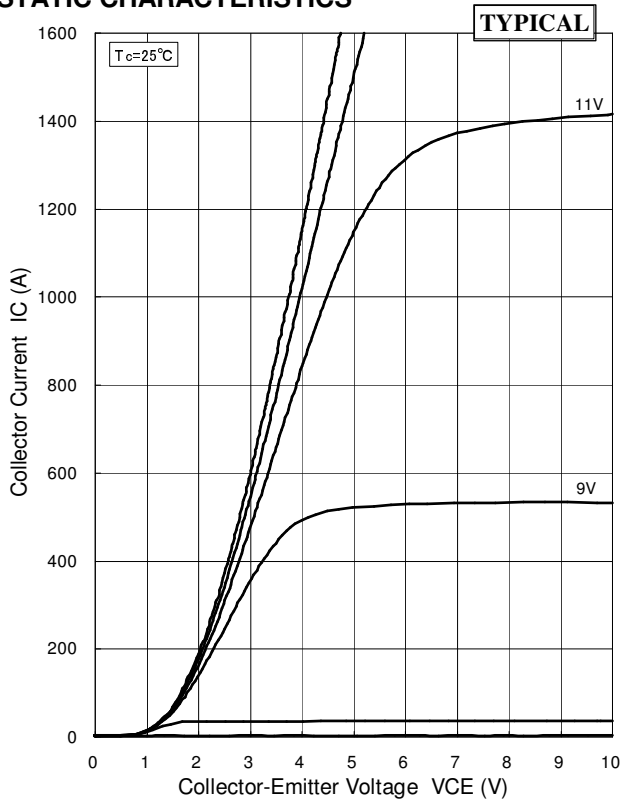

Fig.3 Definition of switching loss

MBL800E33D

CHARACTERISTICS CURVE

STATIC CHARACTERISTICS



Collector Current vs. Collector to Emitter Voltage

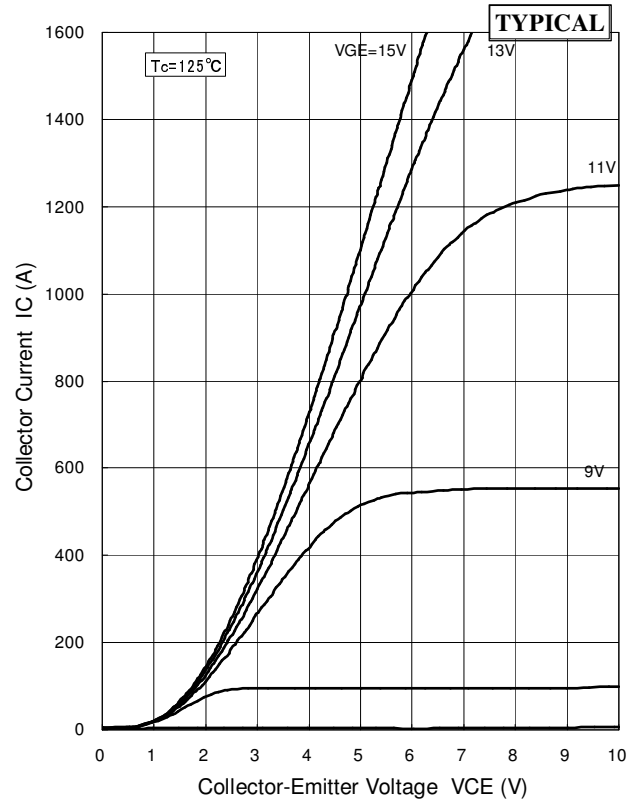

Collector Current vs. Collector to Emitter Voltage

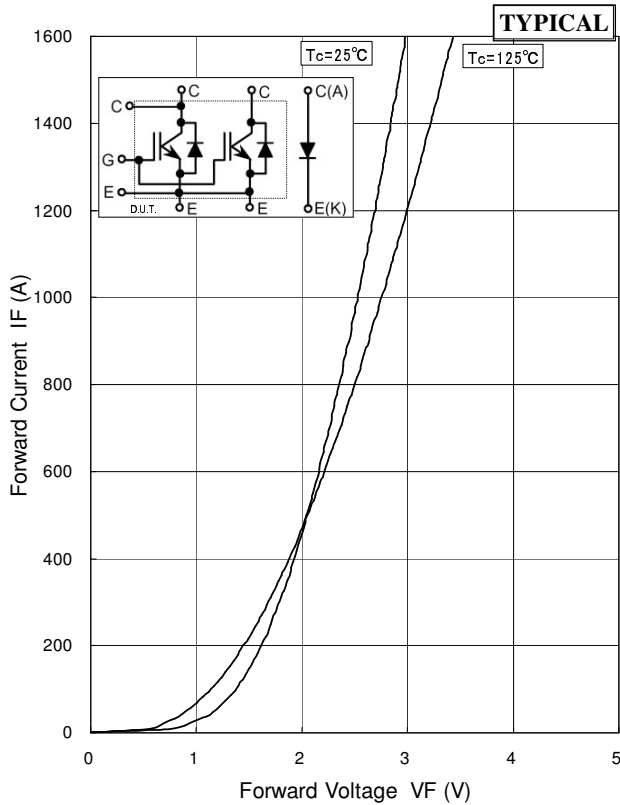

Forward Voltage of free-wheeling diode

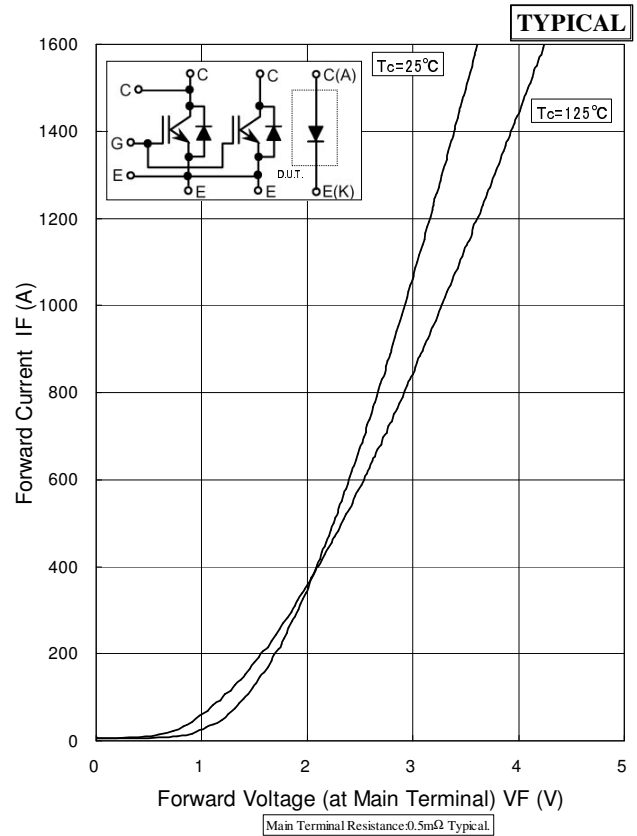

Forward Voltage of chopper diode

MBL800E33D

DYNAMIC CHARACTERISTICS

DEPENDENCE OF CURRENT

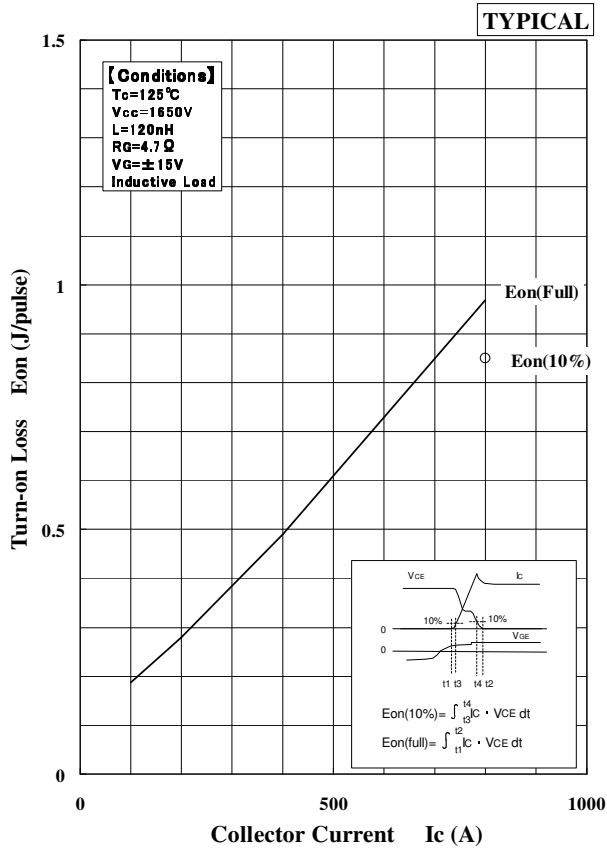

Turn-on Loss vs. Collector Current

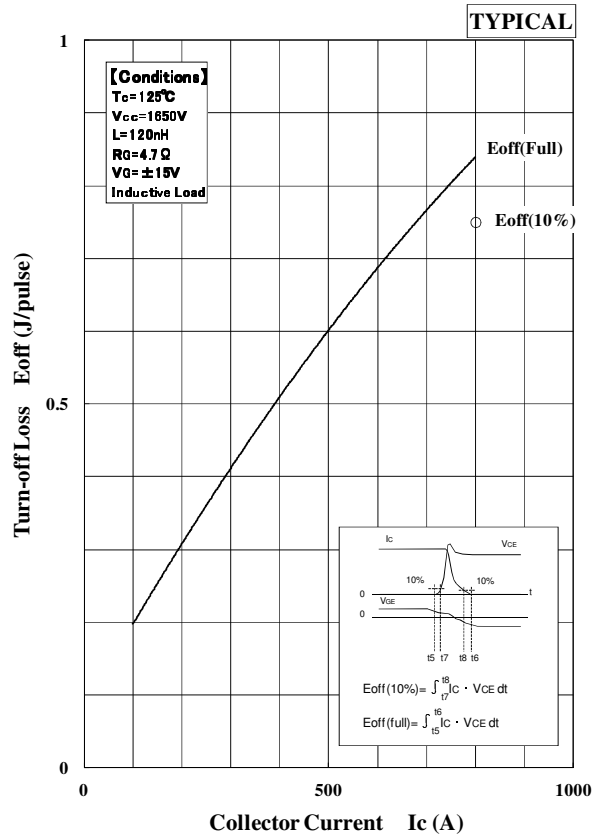

Turn-off Loss vs. Collector Current

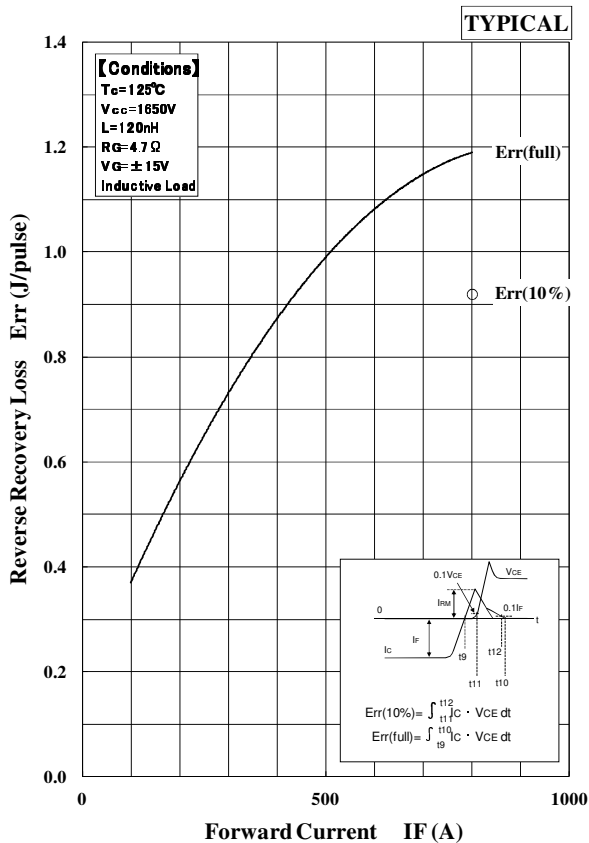

Recovery Loss vs. Forward Current

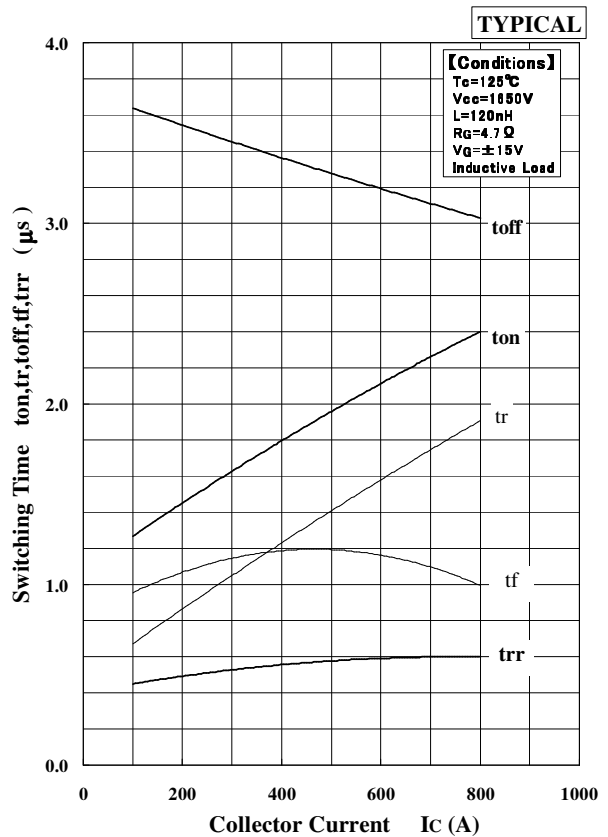

Switching Time vs. Collector Current

MBL800E33D

DEPENDENCE OF RG

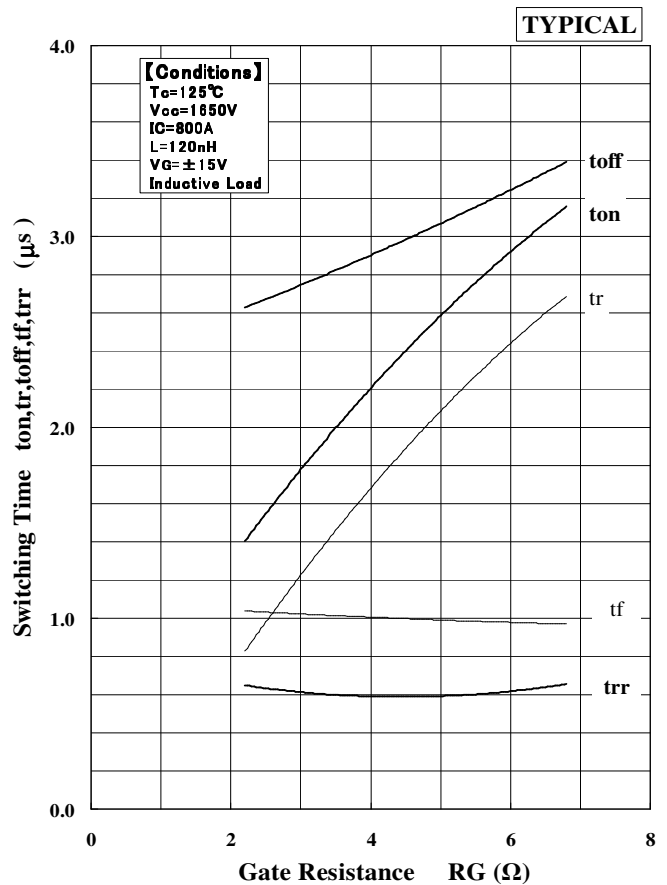
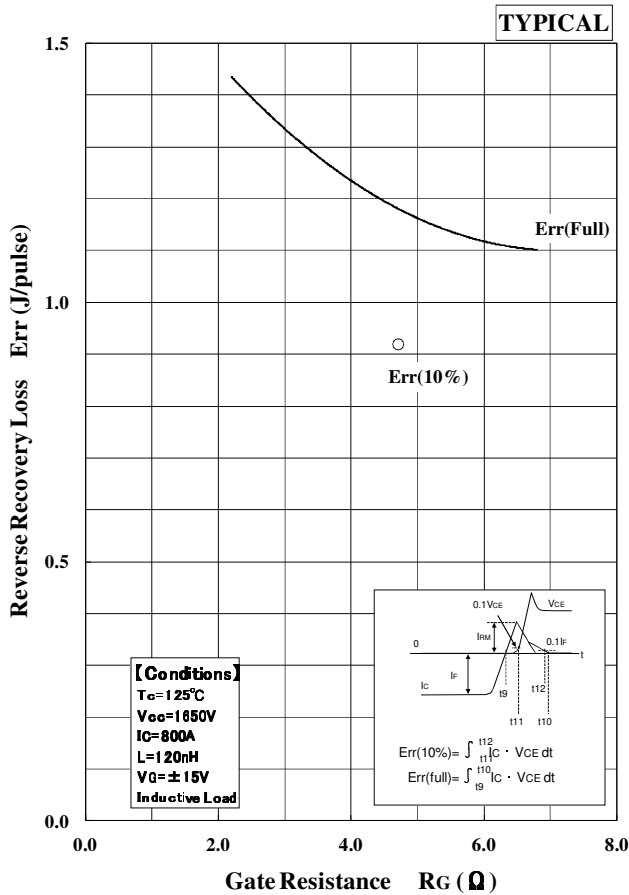
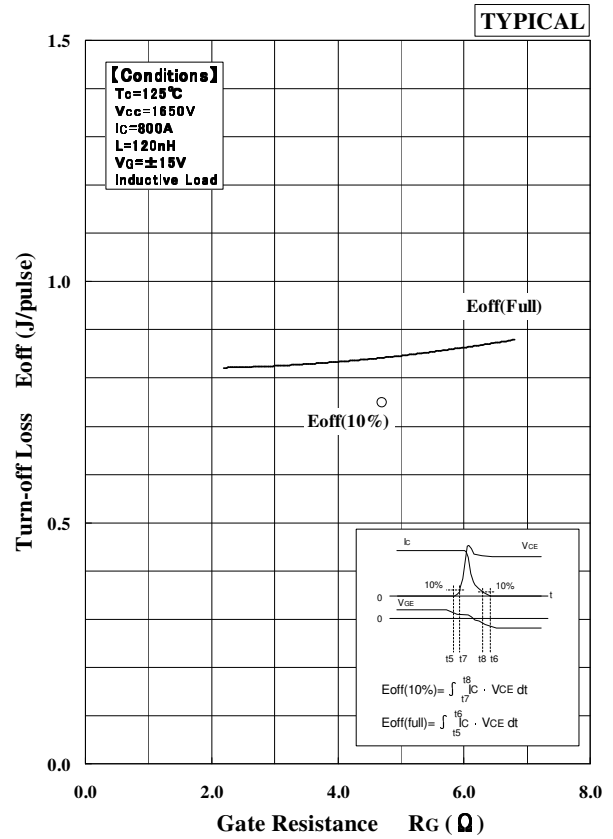
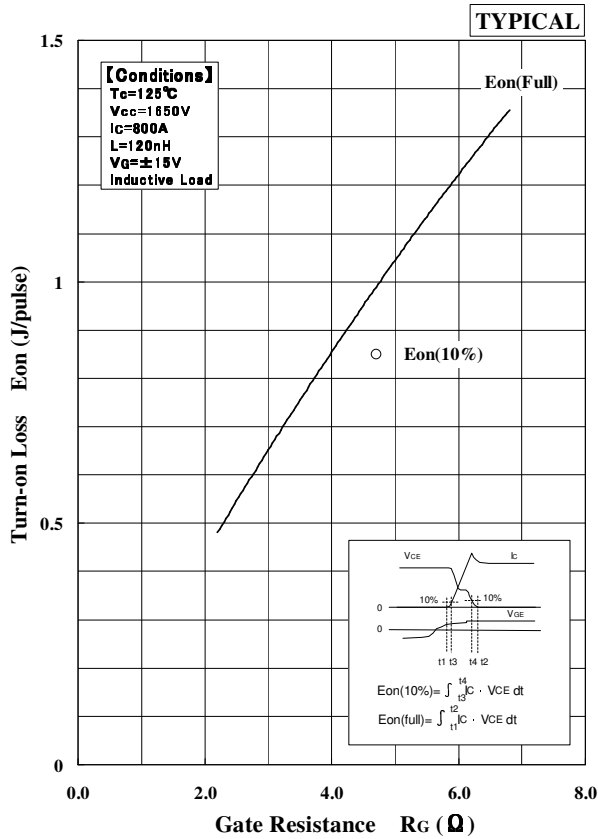

MBL800E33D

PACKAGE OUTLINE DRAWING

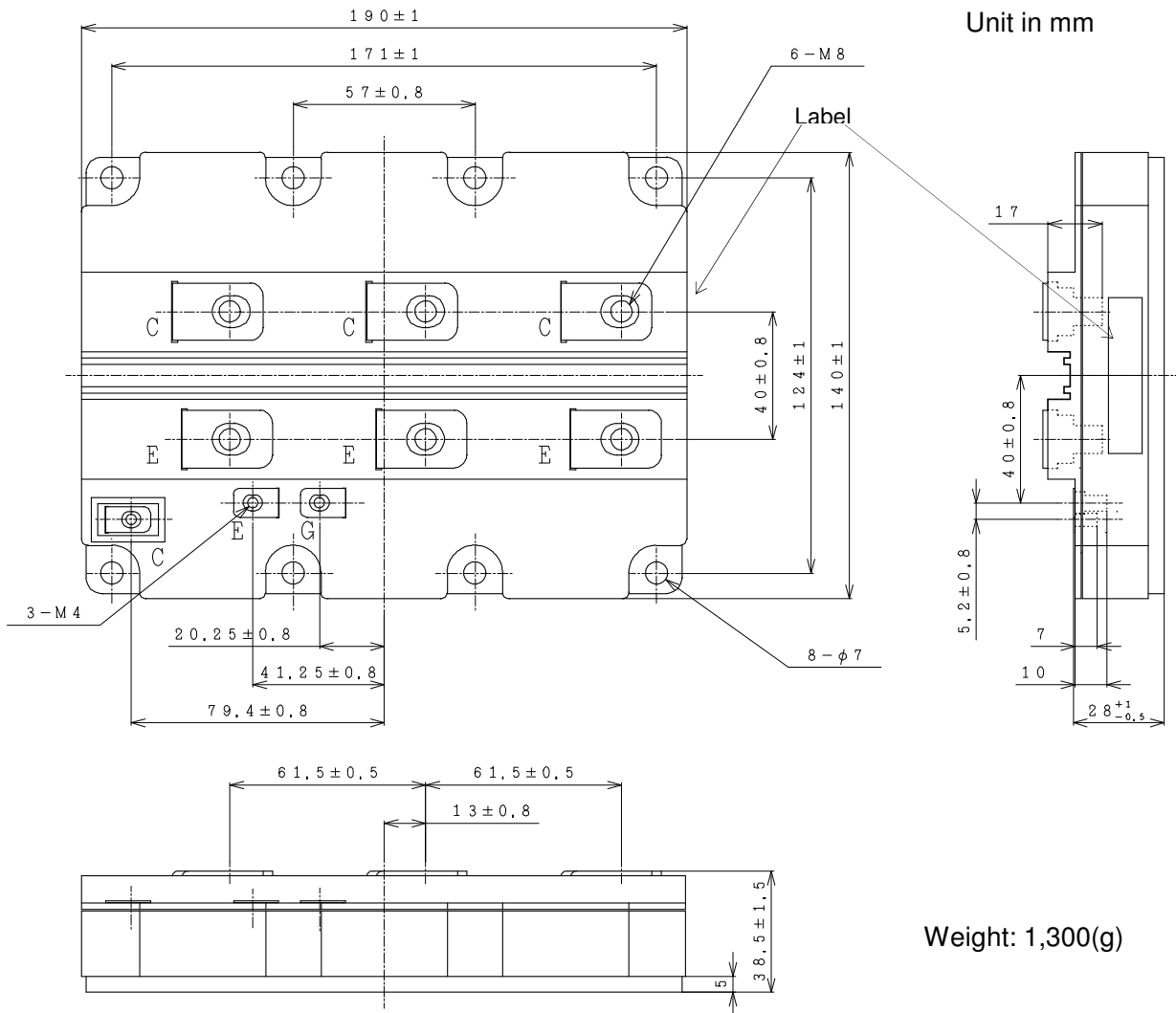

Weight: 1,300(g)

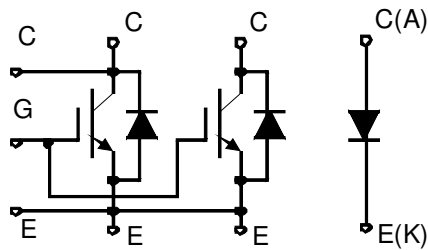

Circuit diagram

MBL800E33D

TRANSIENT THERMAL IMPEDANCE

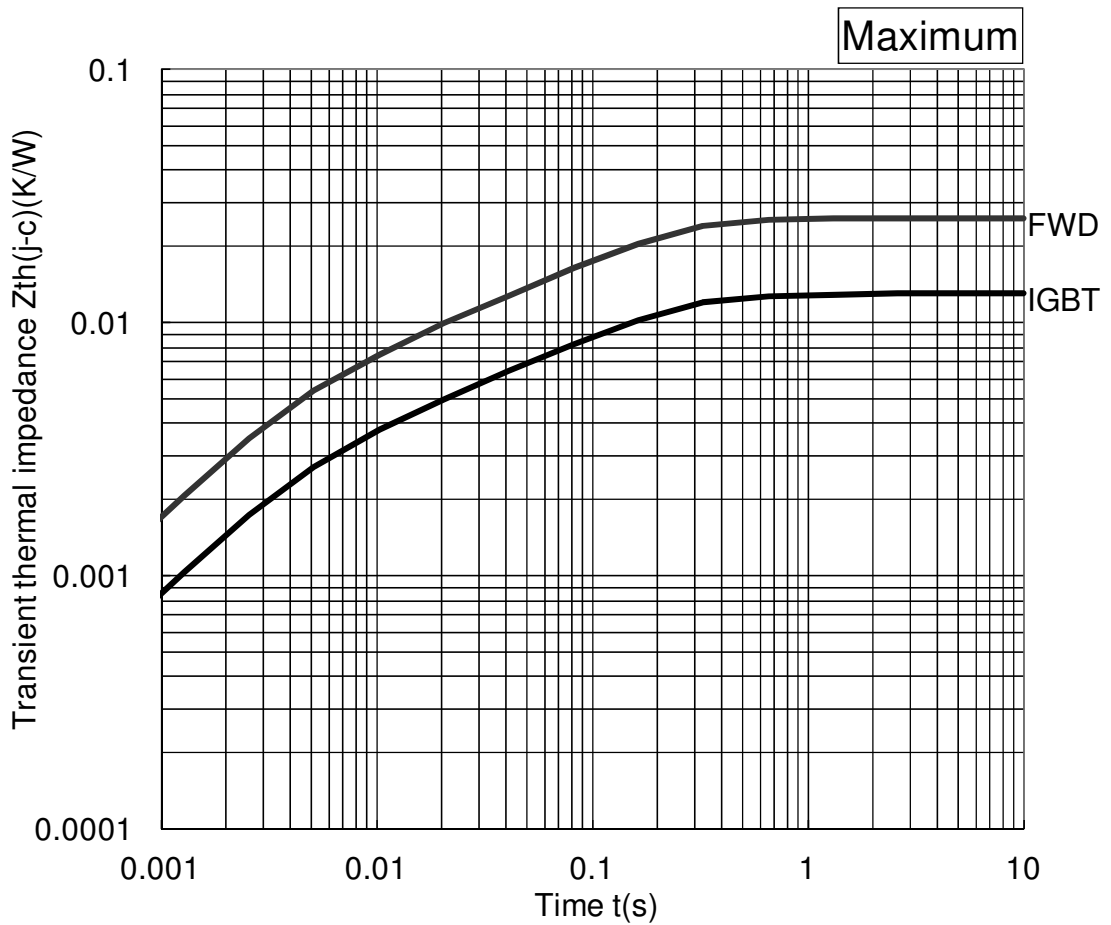

Transient Thermal Impedance Curve

Material declaration

Please note the following materials are contained in the product, in order to keep characteristic and reliability level.

Material	Contained part
Lead (Pb) and its compounds	Solder

MBL800E33D

HITACHI POWER SEMICONDUCTORS

Notices

1. The information given herein, including the specifications and dimensions, is subject to change without prior notice to improve product characteristics. Before ordering, purchasers are advised to contact Hitachi sales department for the latest version of this data sheets.
2. Please be sure to read "Precautions for Safe Use and Notices" in the individual brochure before use.
3. In cases where extremely high reliability is required (such as use in nuclear power control, aerospace and aviation, traffic equipment, life-support-related medical equipment, fuel control equipment and various kinds of safety equipment), safety should be ensured by using semiconductor devices that feature assured safety or by means of users' fail-safe precautions or other arrangement. Or consult Hitachi's sales department staff.
4. In no event shall Hitachi be liable for any damages that may result from an accident or any other cause during operation of the user's units according to this data sheets. Hitachi assumes no responsibility for any intellectual property claims or any other problems that may result from applications of information, products or circuits described in this data sheets.
5. In no event shall Hitachi be liable for any failure in a semiconductor device or any secondary damage resulting from use at a value exceeding the absolute maximum rating.
6. No license is granted by this data sheets under any patents or other rights of any third party or Hitachi Power Semiconductor Device, Ltd.
7. This data sheets may not be reproduced or duplicated, in any form, in whole or in part, without the expressed written permission of Hitachi Power Semiconductor Device, Ltd.
8. The products (technologies) described in this data sheets are not to be provided to any party whose purpose in their application will hinder maintenance of international peace and safety not are they to be applied to that purpose by their direct purchasers or any third party. When exporting these products (technologies), the necessary procedures are to be taken in accordance with related laws and regulations.

-
- For inquiries relating to the products, please contact nearest overseas representatives that is located "Inquiry" portion on the top page of a home page.
-

Hitachi power semiconductor home page address <http://www.hitachi-power-semiconductor-device.co.jp/en/>